

**Kobets A.  
Naumenko N.  
Ponomarenko N.**  
*Dnipropetrovsk State  
Agrarian-Economic  
University*

**Яропуд В.  
Vinnytsia National  
Agrarian University**

**Кобець А.С.**  
д.з держ. упр., професор  
**Науменко М.М.**  
к.т.н., професор  
**Пономаренко Н.О.**  
к.т.н., доцент  
**Дніпровський  
державний аграрно-  
економічний  
університет**

**Яропуд В.М.**  
к.т.н., старший викладач  
**Вінницький  
національний аграрний  
університет**

**УДК 631.333**

## **THE CENTRIFUGAL TYPE MINERAL FERTILIZERS SPREADER**

*The scientific foundations of justification of technological parameters for centrifugal type mineral fertilizers spreaders.*

*It is founded out one of the possible reasons of the uneven dispersion of fertilizers by centrifugal type spreader. Simplified for engineering application formulas are derived, making it possible to justify the construction of fertilizer spreader disk that is guaranteed improves dispersion. Technical means are created and implemented into production.*

**Key words:** *fertilizing, fertilizers, allocation quality, effectiveness of machines, spreader parameters, working modes.*

**Introduction.** The uneven distribution of nutrients by surface of fields affects crop yields. The development of fertilizers favorable primarily in a direction of improving the efficiency of their distribution by improving the quality of their distribution by soil surface. More than 90% of modern fertilizers are equipped with spreading centrifugal working bodies that successfully applies granular and crystalline fertilizers and chemical ameliorants. Fertilizers must apply them accurately (evenly). Nowadays some parameters of fertilizing are too big, so unevenness by working width with machines of domestic production reaches 60-80%, what reduces the efficiency of fertilizers. Thus, the justification and design parameters of the centrifugal working body for fertilizers is an actual task [3-5].

**Literature data analysis.** P. Vasilenko was recognized as founder of the centrifugal type spreaders theory by law. Later theoretical studies were conducted by V. V. Adamchuk, E. V. Kozlovsky, Dohonovsky M. G, M. K. Shtukov, R. M. Hilis, V. F. Yaroshenko, S. I. Nazarov. Among the latest fundamental analytical research

attractes the attention works of V. V. Adamchuk, V. M. Bulgakov, P. M. Zaika, S. F. Pylypaky.

An important contribution to science in sphere of the development and implementation of centrifugal type mineral fertilizers was made by S. I. Volosnykov, S. F. Babaryka, V. N. Dyadya, L. I. Letkovskyy and others.

### **Analytical research of centrifugal spreaders working body sowing process.**

The process of granules distribution by surface of a field has multifactorial probabilistic nature. It is influenced by: normal distribution coefficient of windage, logarithmic law of dependance of on flight distance from windage coefficient, translational motion of the unit law as a whole. Superposition of these laws gives the final picture of the distribution of fertilizers by the surface. In general, the law can not be normal. But if a sufficiently large number of options for starting coming-off of granules from the surface is provided, from the point of view of probability theory, this law will be closer to normal.

Graphical interpretation of this provision is shown on Fig.1.

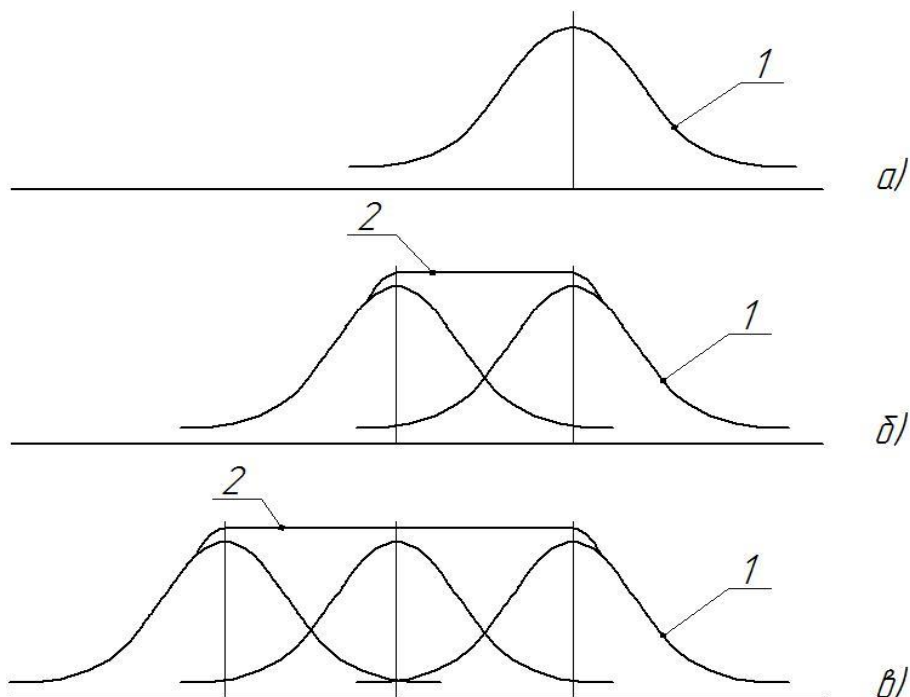
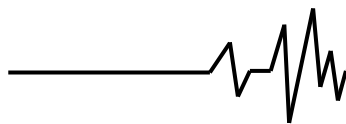

**Fig.1. Graphical interpretation of superposition of laws of fertilizers distribution by surface of a field in presence of one (a) two (b) and three (c) coming-off points from surface of the disc1 - single distribution laws; 2 - area of normal distribution.**

As seen from the above, the usual amount of 1 single distribution laws allows to receive areas 2 close to the normal distribution. Therefore, it is necessary to provide coming-off of multiple streams of granules with different initial velocities, preventing flow crossing during flight.

As analysis of the process of fertilizing showed [1,8-10], centrifugal type spreaders can provide more dense sowing by the edges of coverage. To improve evenness, construction diagram is proposed (Fig. 1), which provides various initial conditions for granules escape from each of three edges placed on four bladed disk.

In accordance with the accepted disk construction, scattering scheme provides that the width of the treated area, where fertilizers apply, divided into three parts. Each edge on the blade should apply fertilizer on the territory assigned to it. In order for this happens, it is necessary to determine the length of each edge, and the its position on the blade. Let us assume that goal will be achieved if the granules on the middle edge will gain escaping velocity enough for sowing area with width  $2/3B$ , and with short edge -  $1/3B$ . Velocity addition theorem is used to determine the escaping velocity of fertilizer from edge, which starts at an arbitrary distance  $a$  from the center of disk.

$$\bar{V} = \bar{V}_r + \bar{V}_e, \tag{1}$$

where  $\bar{V}_r$  – the relative velocity along the

guiding edge;

$\bar{V}_e$  – transient velocity, which for escaping from disk fertilizer determined by known angular velocity  $\omega$  of disk and edge length  $l$  as

$$\bar{V}_e = \omega \cdot \sqrt{l^2 \cos^2 \alpha + a^2}.$$

The relative speed can be found by the theorem of changing of kinetic energy in relative motion from formula [6]

$$\frac{mV^2}{2} - \frac{mV_0^2}{2} = A(F_e) + A(F_{m1}) + A(F_{mp}) + A(P), \tag{2}$$

where  $A(F_e)$  – work of transient force of inertia  $F_e$  on moving along the edge;  $A(F_{mp})$  – work of the friction force that occurs on the surface of the blade because of force action  $F_e$  and fertilizer weight  $P$ ;  $A(F_{m1})$  – work of the friction force that occurs on surface of the vertical edge from the Coriolis force of inertia  $F_c$  and transient force  $F_e$ ;  $A(F_e)$  – work of weight force;  $V_0$  – initial relative velocity.

Work of transient inertial forces on movement defines as

$$A(F_e^{in}) = \frac{1}{2} m \omega^2 (R_k^2 - a^2). \tag{3}$$

Friction force on the surface of blade  $F_{m1}$  determined through the normal reaction  $N_1$ , which is due fertilizer weight  $P$  and transient inertial force  $F_e^{in}$

$$N_1 = P \cos \alpha + F_e^{in} \sin \psi \sin \alpha.$$

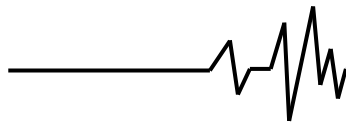

$$\text{Then } F_{ma} = f \left( mg \cos \alpha + m\omega^2 r \cdot \frac{x}{r} \cos \alpha \sin \alpha \right) = fm(g \cos \alpha + \omega^2 x \cos \alpha \sin \alpha),$$

Where  $f$  – friction coefficient.

Work of the friction force on the surface of blade  $A(F_{mn})$  defines as

$$A(F_{ma}) = -fmg\sqrt{R_k^2 - a^2} - fm\omega^2 \cdot \frac{1}{2}(R_k^2 - a^2) \sin \alpha / \cos \alpha. \quad (4)$$

Friction force on the edge surface is defined as

$$F_{mp} = f(2m\omega V_r \cos \alpha - m\omega^2 a). \quad (5)$$

Work of this force is defined as

$$A(F_{mp}) = -\int_0^l 2f m\omega V_r \cos \alpha dx + \int_0^l f m\omega^2 a dx. \quad (6)$$

Assuming that initial relative velocity  $V_0 = \omega a \cos \alpha$  for  $A(F_{mp})$  we will get

$$A(F_{mh}) = -fm\omega(\omega a \cos \alpha + V)\sqrt{R_k^2 - a^2} + fm\omega^2 a \cdot \sqrt{R_k^2 - a^2} / \cos \alpha. \quad (7)$$

Work of weight force  $P$  defines as

$$A(P) = -mgl_k \sin \alpha. \quad (8)$$

Substituting expressions (3), (4), (7), (8) into formula (2) we will get

$$\begin{aligned} \frac{mV^2}{2} - \frac{mV_0^2}{2} = & \frac{1}{2} m\omega^2 (R_k^2 - a^2) - fmg\sqrt{R_k^2 - a^2} - fm\omega^2 \cdot \frac{1}{2}(R_k^2 - a^2) \sin \alpha / \cos \alpha - \\ & - fm\omega(\omega a \cos \alpha + V)\sqrt{R_k^2 - a^2} + fm\omega^2 a \sqrt{R_k^2 - a^2} / \cos \alpha - mgl_k \sin \alpha. \end{aligned} \quad (9)$$

If into the last expression substitute distance from center to the first edge ( $a = a_1$ ), we will get

$$\begin{aligned} \frac{mV^2}{2} - \frac{m}{2} \omega^2 a_1^2 \cos^2 \alpha = & \frac{1}{2} m\omega^2 (R_k^2 - a_1^2) - fmg\sqrt{R_k^2 - a_1^2} - \frac{1}{2} fm\omega^2 \cdot (R_k^2 - a_1^2) \sin \alpha / \cos \alpha - \\ & - fm\omega^2 \cos \alpha \sqrt{R_k^2 - a_1^2} - fmV\sqrt{R_k^2 - a_1^2} + \frac{fm\omega^2 a_1 \sqrt{R_k^2 - a_1^2}}{\cos \alpha} - mgl_k \sin \alpha. \end{aligned}$$

Where for the relative velocity on escaping from the long edge you can get

$$V = -c_1 + \sqrt{c_1^2 + c_2}, \quad (10)$$

$$\text{where } c_1 = f\omega\sqrt{R_k^2 - a_k^2},$$

$$\begin{aligned} c_2 = & \omega^2 a_1 \cos^2 \alpha \left( a_1 \cos \alpha - 2f\sqrt{R_k^2 - a_1^2} + \omega^2 (R_k^2 - a_1^2) \right) (1 - f \sin \alpha / \cos \alpha) - \\ & - 2fg\sqrt{R_k^2 - a_1^2} + 2f\omega^2 a_1 \sqrt{R_k^2 - a_1^2} / \cos \alpha - 2gl_k \sin \alpha. \end{aligned}$$

Then definition of absolute velocity is:

$$V_a = \sqrt{(V_a \cos \alpha_0)^2 + (V_r \sin \alpha)^2}, \quad (11)$$

where  $\alpha_0$  – angle of fertilize escaping;  $V_a \cos \alpha_0$  – projection of escaping velocity on a horizontal plane;  $V_r \sin \alpha_0$  – projection of escaping velocity on a vertical plane.

Than for escaping angle we can get

$$\alpha_0 = \arccos \sqrt{(V_r \cos \alpha_0)^2 + V_e^2 + 2V_e V_r \cos \alpha \cos \gamma / V_a}. \quad (12)$$

These formulas allow to justify some constructional characteristics of the spreader. Calculations are made by the following initial data: angular disk velocity  $\omega = 57,6 \text{ rad/sec}$ ; disk radius  $R = 0,3 \text{ m}$ ; blade inclination angle  $\alpha = 0,5236 \text{ rad}$ ; friction coefficient of fertilize by the blade surface  $f = 0,35$ .

Analysis of possible options of constructions of centrifugal working body for fertilizing allowed to accept spreader scheme, construction of which involves formation arrangement of granule flows when loading. To perform the task working body scheme is proposed – Fig.1.

Spreader consists of disk 17, four blades

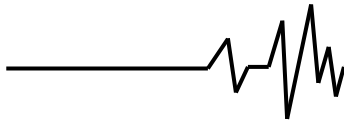

(sectors 11–14), each of which is formed by two blades whose side walls are formed by vertical edges and bottoms are inclined at angles  $\alpha_1$  and  $\alpha_2$  to horizontal disk surface. Each edge (1–3) is perpendicular to the common line of intersection blades bottoms and disk plane (at Fig.1 directions of each edge marked with angles  $\gamma_1, \gamma_2, \gamma_3$  accordingly). In the center of the disc there is a conical feeder 4, interior space of which is divided into separate sectors by radial vertical plates (6–10). Each plate at the bottom part goes beyond the feeder on edge height and by bottom part attached to horizontal central part of the disk. The lateral end of protruding from the feeder part (conical) is connected to the curvilinear section of the edge 2, which is placed on the horizontal plane of the disk.

In the same way edge 3 is connected to the protruding side end of the plate 8, and edge 1 – with 9. In each quarter of the centrifugal working body where the working blade is, feeder divided into four sectors by plates. Three of them workable, through two blades fertilizer fall on upper disk, and on the second sector accounts 53,6 % amount of fertilizer from first, and onto the last – third – the least 11,24 % of the same amount. From this sector fertilizer falls onto disk 15, which is situated lower on 60 mm from the upper which is provided by cup 5, on which are placed perpendicular one to each other guiding edges 16. One of feeder sectors closed from above (fig.1,

shaded). Sectors areas are assigned proportional to the expenditure of material which falls on each edge. The material getting into the sectors falls on the horizontal surface of the disc from which, moves between the curved portions of edges gets to the inclined blades.

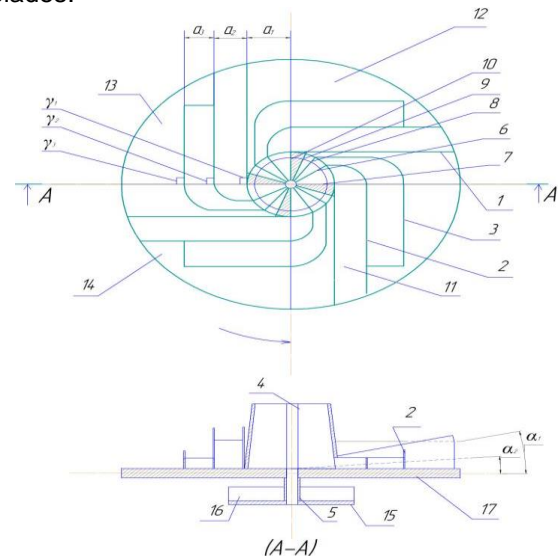

**Fig.1. Constructive and technological scheme of the centrifugal working body for fertilization**

At fig.2 there is a scheme, which qualitatively describes the distribution of granules by simultaneous dispersion with three edges.

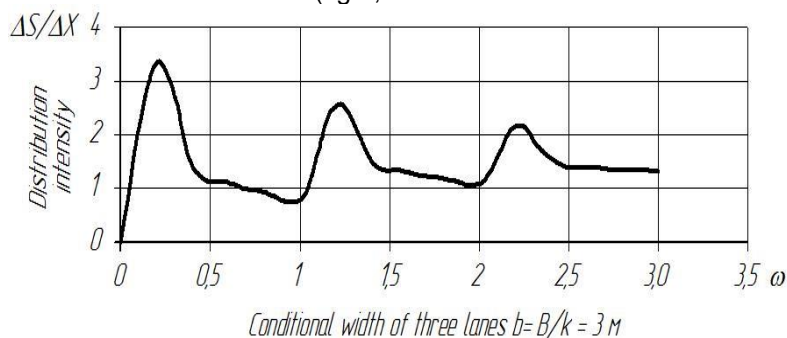

**Fig. 2. Distribution of three streams**

As we can see, areas are limited by intensity distribution curve, on each of the three units of bandwidth capture approximately the same, so on each lane approximately the same number of granules. Relatively to uneven distribution of granules within a lane, we can note that above-mentioned situation is idealized and includes: all granules flies on the same distance during work of one of the edges. The reality is that the granules are not identical in shape and capacity. They have different aerodynamic characteristics, providing a different range of flight and improves uniformity of distribution which can be tested experimentally.

**Conclusions.** In this paper, the scientific and appliance problem of efficiency improvement

of mechanical application of solid fertilizers is solved through improvement of quality of their distribution by the surface of soil and increasing of machine productivity.

1. New construction of spreader is proposed, which can realize better uniform dispersion, in condition of ensuring of individual supply of each of three streams of granules, which are escaping from disc.

2. Fairly simple formulas for engineering application are derived, which gives the possibility to justify the construction of disk fertilizers spreader, which improves dispersion guaranteed.

3. The resulting formula can determine the absolute velocity of fertilizer escaping from the disc and the angle of escaping that are necessary to

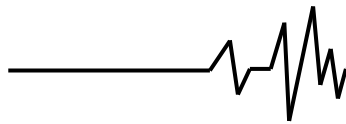

determine the operation width of spreader.

#### List of references

1. Кобець А.С. Обґрунтування конструкції чотирилопатевого відцентрового розкидача мінеральних добрив / М.М. Науменко, Н.О. Пономаренко. // Вісник Дніпропетровського державного університету – 2013. – С.65–67.

2. Василенко П.М. Теория движения частицы по шероховатым поверхностям сельскохозяйственных машин / Василенко П.М. - Изд-во Украинской академии сельскохозяйственных наук. Киев – 1960.–283 с.

3. Адамчук В.В. Механіко-технологічні і технічні основи підвищення ефективності внесення твердих мінеральних добрив та хіммеліорантів: Автореф. дис. док. техн. наук: 05.05.11. – Національний аграрний університет, Київ, 2006. – 45 с.

4. Сметнев С.Д. «Состояние и перспектива механизации применения минеральных удобрений «Механизация и электрификация социалистического сельского хозяйства» – 1971, №5. – 189 с.

5. Кравчук В.І. Сучасні тенденції розвитку конструкції с/г техніки/ М.І. Грицигінна, С.М. Ковалія, - К.: Аграрна наука, 2004. – 396 с.

6. Яблонський А.А. "Теоретическая механика", том 1 - Статика и кинематика, 1967г., 512 с.

7. Фихтенгольц. Курс дифференциального и интегрального исчисления / Фихтенгольц. Том 2 «Наука». М., 1970, - 800 с.

8. Mitchell D. Uneven applikationleads to clacre gran losses / D. Mitchell // Power Farmg. – 1974. – № 5. – S. 8–9.

9. Thimon J. Uneven distributon can no longer be baken for granted / J. Thimon // Fertilirer Solution. – 1974. – № 18. – S. 6.

10. Wiemann K. Richtiy Verteiet wirkt Dunger besser / K. Wiemann // Ubersicht. – 1973. – G. 24. – № 10. – S. 765–769.

#### Список джерел в транслітерації

1. Kobets A.S. Obhruntuvannya konstruktsiyi chotyrylopatevoho vidtsentrovoho rozkydacha mineralnykh dobrovy / M.M. Naumenko, N.O. Ponomarenko. // Visnyk Dnipropetrovskoho derzhahrouniversytetu – 2013. – P.65–67.

2. Vasylenko P.M. Teoryya dvyzhenyya chastytsy po sherokhovatym poverkhnostyam selskokhozyaystvennykh mashyn / Vasylenko P.M.- Yzd-vo Ukraynskooy akademyyi selskokhozyaystvennykh nauk. Kyev – 1960. – 283 P.

3. Adamchuk V.V. Mekhaniko-tekhnolohichni i tekhnichni osnovy pidvyshchennya efektyvnosti vnesennya tverdyykh mineralnykh dobrovy ta khimmeliorantiv: Avtoref.

dys. dok. tekhn. nauk: 05.05.11. – Natsionalnyy ahrarnyy universytet, Kyiv, 2006. – 45 P.

4. Smetnev S.D. «Sostoyanye u perspektyva mekhanyzatsyy pryomenenyya myneralnykh udobrenyy «Mekhanyzatsyya u élektryfykatsyya sotsyalystycheskoho selskoho khozyaystva» - 1971, №5. – 189 P.

5. Kravchuk V.I. Suchasni tendentsiyi rozvytku konstruktsiyi s/h tekhniky/ M.I. Hrytsyhinna, S.M. Kovalya, - K.: Ahrarna nauka, 2004. – 396 P.

6. Yablonskyu A.A. "Teoretycheskaya mekhanyka", tom 1 - Statyka u kynematyka, 1967h., 512 P.

7. Fykhtenholts. Kurs dyfferentsyalnoho u yntehralnoho yscheslenyya / Fykhtenholts. Tom 2 «Nauka». M., 1970, - 800 P.

8. Mitchell D. Uneven applikationleads to clacre gran losses / D. Mitchell // Power Farmg. – 1974. – № 5. – P. 8–9.

9. Thimon J. Uneven distributon can no longer be baken for granted / J. Thimon // Fertilirer Solution. – 1974. – № 18. – P. 6.

10. Wiemann K. Richtiy Verteiet wirkt Dunger besser /K. Wiemann// Ubersicht. – 1973. – G. 24. – № 10. – P. 765–769.

#### РОЗКИДАЧ МІНЕРАЛЬНИХ ДОБРИВ ВІДЦЕНТРОВОГО ТИПУ

*В науковій статті наведено обґрунтування технологічних параметрів розкидача мінеральних добрив відцентрового типу.*

*Виявлено одну з можливих причин нерівномірного розсіювання добрив розкидачем відцентрового типу. Отримано спрощену формулу для інженерних розрахунків, що дає можливість обґрунтувати конструкцію диска розкидача добрив, яка гарантує покращення дисперсії. Запропонований розкидач мінеральних добрив відцентрового типу можливий до впровадження у виробництво.*

*Ключові слова:* внесення добрив, добрива, якість розподілу, ефективність машин, параметри розкидачів, режими роботи.

#### РАЗБРАСЫВАТЕЛЬ МИНЕРАЛЬНЫХ УДОБРЕНИЙ ЦЕНТРОБЕЖНОГО ТИПА

*В научной статье приведено обоснование технологических параметров разбрасывателя минеральных удобрений центробежного типа.*

*Обнаружена одна из возможных причин неравномерного внесения удобрений разбрасывателем центробежного типа. Получено упрощенную формулу для*

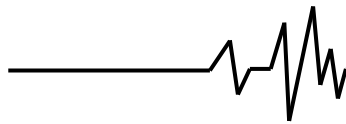

инженерных расчетов, которая дает возможность обосновать конструкцию диска разбрасывателя удобрений, которая гарантирует улучшения дисперсии. Предложенный разбрасыватель минеральных удобрений центробежного типа возможен до

внедрения в производство.

**Ключевые слова:** внесение удобрений, удобрения, качество распределения, эффективность машин, параметры разбрасывателя, режимы работы.

#### **Information about the authors**

**Kobets A.S.** – doctor of public administration, professor of the department of agricultural machines of Dnipro national agrarian-economic university (St.S.Efremova, 25, Dnipro, Ukraine, 49000)

**Naumenko N.N.** – candidate of technical sciences, professor of the department of theoretic mechanic and material recovery of Dnipro national agrarian-economic university (St.S.Efremova, 25, Dnipro, Ukraine, 49000, e-mail: nnitf@ukr.net)

**Ponomarenko N.A.** – candidate of technical sciences, assistant professor of the department of exploitation machinery-tractor park of Dnipro national agrarian-economic university (St.S.Efremova, 25, Dnipro, Ukraine, 49000, e-mail: nanagieva@ukr.net)

**Yaropud V.M.** – candidate of technical sciences, senior lecturer of the department of agricultural machines of Vinnytsia national agrarian university (St.Soniachna, 3, Vinnytsia, Ukraine, 21008, e-mail: yaropud77@gmail.com)

**Кобець Анатолій Степанович** – доктор з державного управління, професор кафедри сільськогосподарських машин Дніпровського державного аграрно-економічного університету (вул. Сергія Єфремова, 25, м. Дніпро, Україна, 49000)

**Науменко Микола Миколайович** – кандидат технічних наук, професор кафедри теоретичної механіки та опору матеріалів Дніпровського державного аграрно-економічного університету (вул. Сергія Єфремова, 25, м. Дніпро, Україна, 49000, e-mail: nnitf@ukr.net)

**Пономаренко Наталія Олександрівна** – кандидат технічних наук, доцент кафедри експлуатації машинно-тракторного парку Дніпровського державного аграрно-економічного університету (вул. Сергія Єфремова, 25, м. Дніпро, Україна, 49000, e-mail: nanagieva@ukr.net)

**Яропуд Віталій Миколайович** – кандидат технічних наук, старший викладач кафедри сільськогосподарських машин Вінницького національного аграрного університету (вул. Сонячна, 3, м. Вінниця, Україна, 21008, e-mail: yaropud77@gmail.com)

**Кобець Анатолий Степанович** – доктор государственного управления, профессор кафедры сельскохозяйственных машин Днепропетровского государственного аграрно-экономического университета (ул. Сергея Ефремова, 25, г. Днепр, Украина, 49000)

**Науменко Николай Николаевич** – кандидат технических наук, профессор кафедры теоретической механики и сопротивления материалов Днепропетровского государственного аграрно-экономического университета (ул. Сергея Ефремова, 25, г. Днепр, Украина, 49000, e-mail: nnitf@ukr.net)

**Пономаренко Наталья Александровна** – кандидат технических наук, доцент кафедры эксплуатации машинно-тракторного парка Днепропетровского государственного аграрно-экономического университета (ул. Сергея Ефремова, 25, г. Днепр, Украина, 49000, e-mail: nanagieva@ukr.net)

**Яропуд Виталий Николаевич** – кандидат технических наук, старший преподаватель кафедры сельскохозяйственных машин Винницкого национального аграрного университета (ул. Солнечная, 3, г. Винница, Украина, 21008, e-mail: yaropud77@gmail.com)